

Innovative Technology Delivers Silent, Efficient and Long Lasting Ventilation

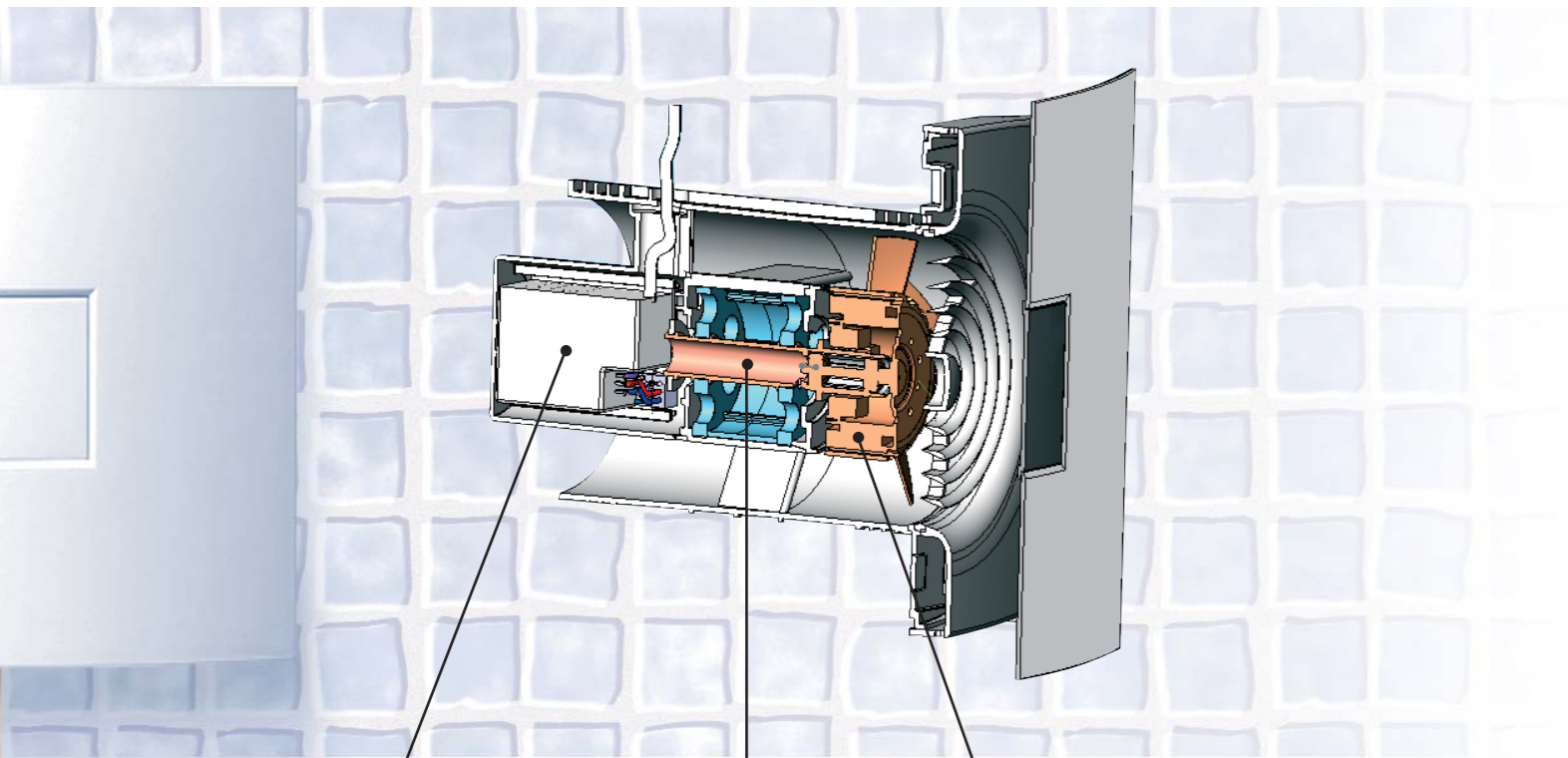

Control Technology

Constant volume sensors maximise ventilation efficiency through the delivery of only the required levels of airflow for the dwelling.

Patented Technology

Anti-vibrational components ensure operational noise is significantly reduced to offer silent ventilation to occupants.

Motor Technology

Electronically commutated, low energy motor reduces friction and heat-build during operation, lengthening life of motor.

Unity Technical Specification

Physical Specification

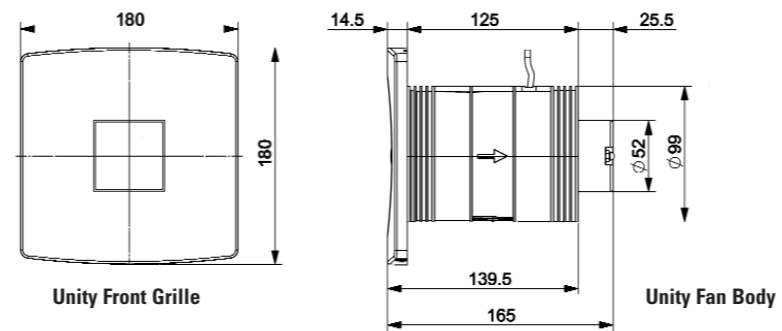

Weight – 1kg

Material – White gloss finish, ABS Plastic Manufacture.

Performance Overview

Model	Airflow Performance (l/s)			Sound Pressure Level@3m dB(A)		Energy Consumption Watts			
	Constant Low	Constant High	Intermittent Boost	Constant	Boost	Low	High	Boost	Maximum
CV100	5	10	15	10	14	1.8	2.2	2.5	5.5
CV100SV	5	10	15	10	14	1.8	2.2	2.5	5.5
CV100WK	Window Kit Installation Option								
CV100PFA	150mm Wall Installation Plate								

Constant Volume Airflow Performance

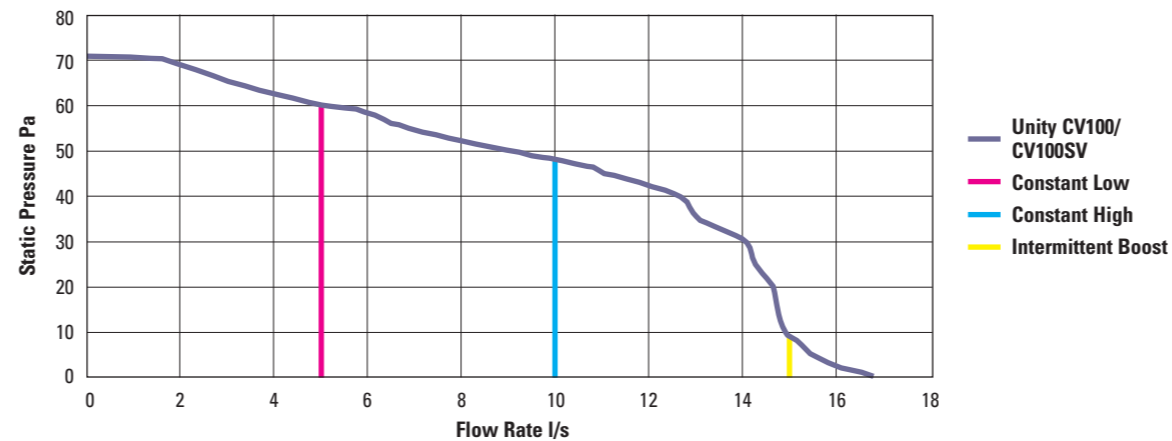

Making Comparisons

Noise Sound Pressure @3m dB(A)	Low Speed	High Speed	Measuring Energy Consumption	Speed l/s (ventilation)	Energy Consumption Watts (at operation)
Unity CV100	10	14	Unity CV100	15 (boost)	2.5
Traditional Continuously Running System	22	36	Select AXS100	15 (single speed)	25
Traditional Extract Fan	35.1 (single speed)		Energy Saving Light Bulb	N/a	15

Installation & Wiring Diagrams

Full details available to download from www.greenwood.co.uk/unity or by contacting Customer Services on 0870 900 1880.

Greenwood Air Management, Greenwood House, Brookside Avenue, Rustington, West Sussex BN16 3LH. Tel: 01903 771021 Fax: 01903 782398 Email: info@greenwood.co.uk Web: www.greenwood.co.uk



an Olixia company



Unity – the single solution extract fan for a risk-free specification

Silence – No risk of noise

- The only silent extract fan on the market
- No more nuisance noise for occupants

Style – No more ugly fans

- Discreet ventilation in a unique way – a fan that doesn't even look like a fan
- Easy to keep clean
- Alternative grilles options available to complement interior design preferences

Simplicity – No change, one product to order

- One Fan, Any Room, All Applications – simply the only fan you will ever need to specify
- Standardised installation, design and cost
- No need to change drawings

*One fan, any room,
all applications...*

Unity

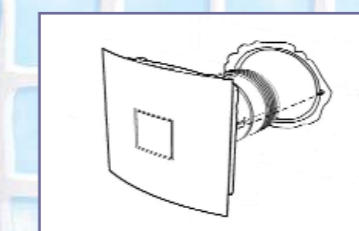

Wall mounted

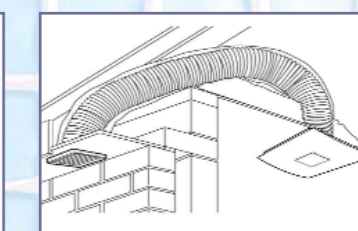

Ceiling mounted

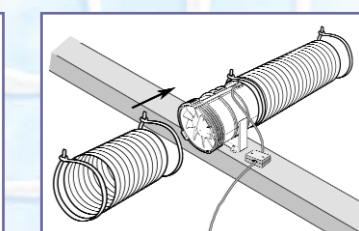

In-line mounted

Safe and Secure – No health and safety problems

- Regulation Compliance at every level – Part F, L and J – no under ventilation, no energy penalty, no gas spillage
- Smaller penetrations in building fabric, improving privacy and security for occupants

Guaranteed Installed Performance – No risk of non-compliance

- Constant volume technology, guaranteeing building ventilation requirements
- Electronic motor control lengthens life of motor

Energy Efficient – No energy penalties

- Unity uses minimal energy use – as little as 2 watts of power
- Provides continuous ventilation for the dwelling in a controlled way

Unity – The fan with all of the answers...